

FIG. 8-1

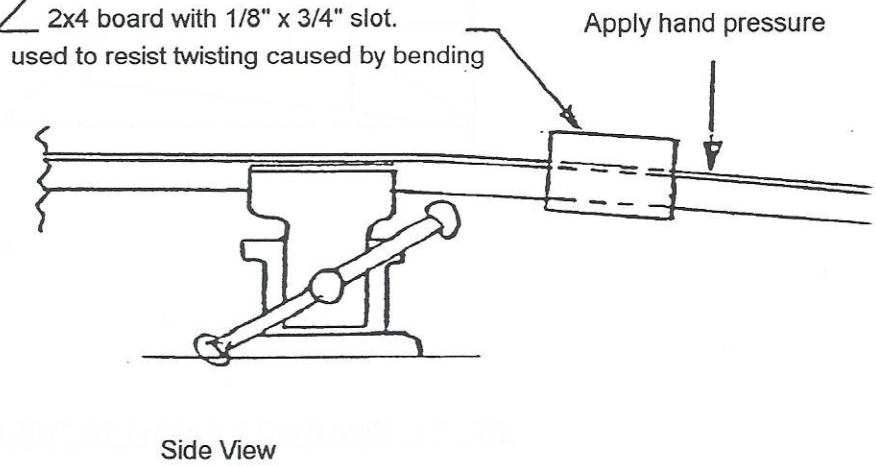
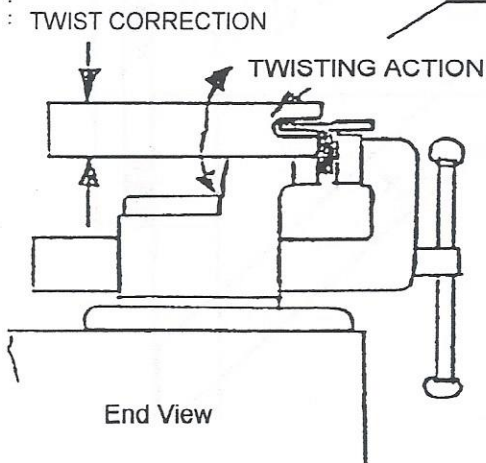
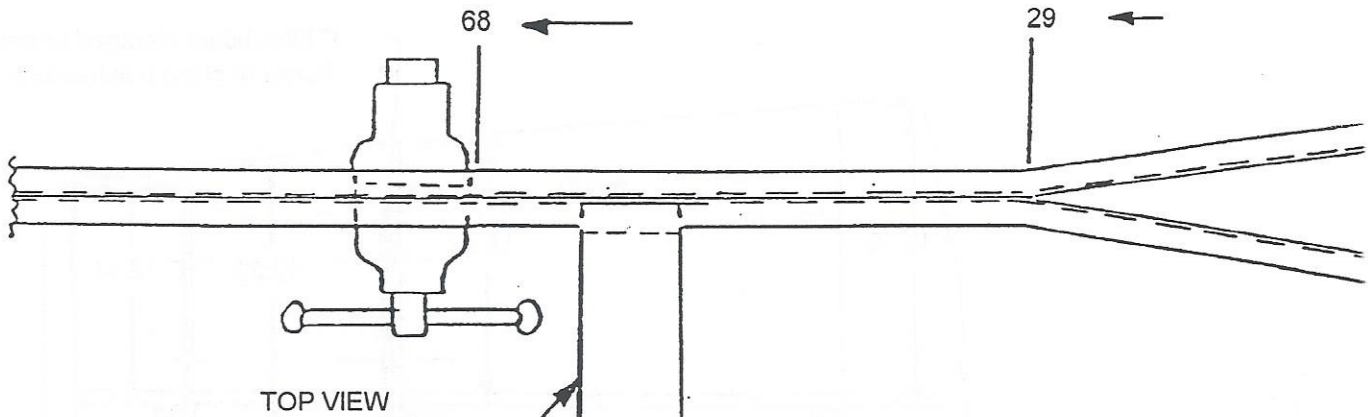
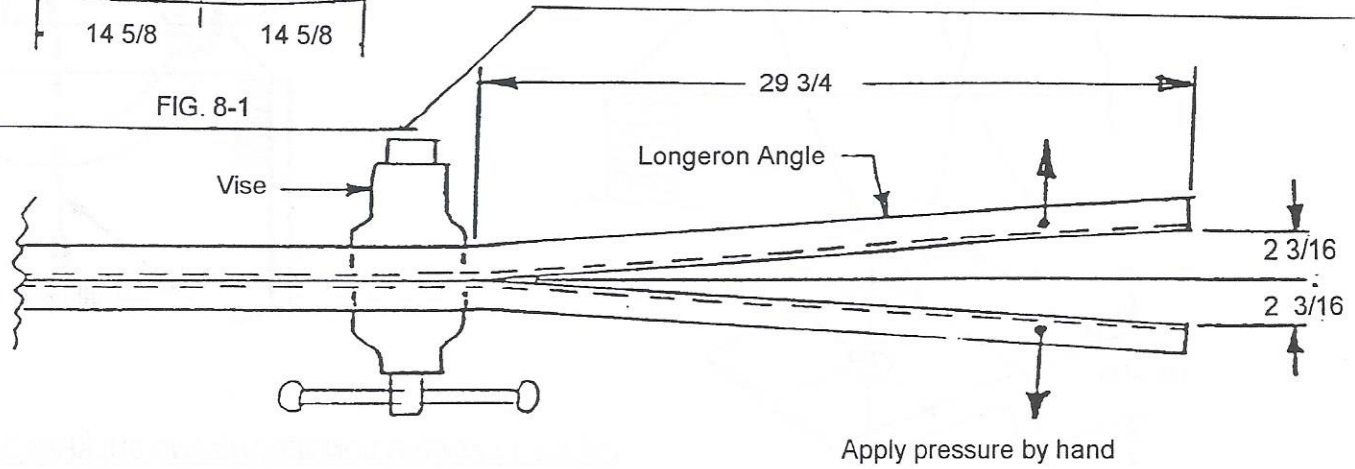

FIG 8-2. BENDING THE LONGERONS